

# Studio Furniture Instruction Sheet

## Config-u-raxx Bridges:

RB-36, RB46 and RB-60

(including CBS Center Bridge Support)

Step 1: First, unpack the shelf and place it and the parts on a table or a carpeted floor.

In the package you will find:

- 1 shelf (36", 46", or 60" long)
- 2 uprights
- 4 screws

If you are adding our optional CBS Center Bridge Support, you'll want to mount it at the same time.

it consists of:

- 1 upright
- 1 receiver
- 8 screws

Mount the uprights to the underside of the shelf as shown, using 2 screws each.

Again, only if you are adding the optional Center Bridge Support, screw the "receiver" in place on the underside of the table top, using 2 of the same screws.

Raxxess Metalsmiths  
261 Buffalo Avenue  
Paterson, N.J. 07503  
Made with pride in the U.S.A.

Page 1 of 2

Upright for  
Optional  
Center Bridge  
Support

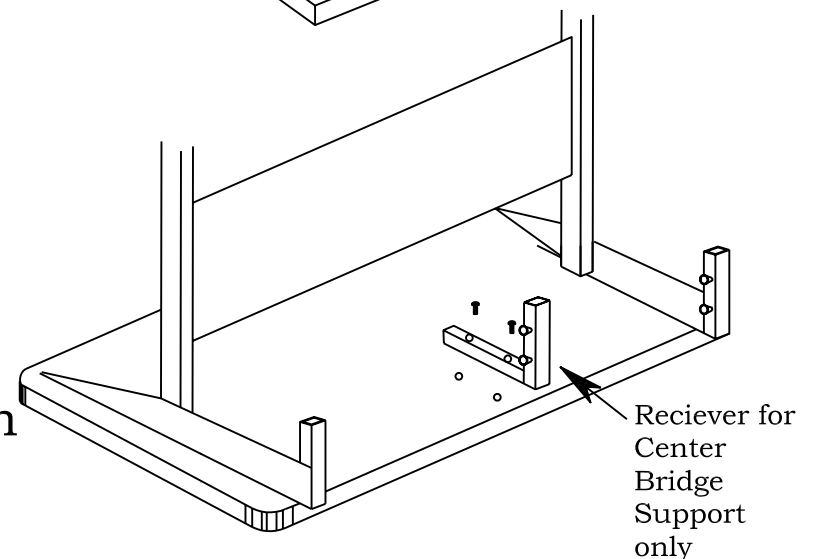
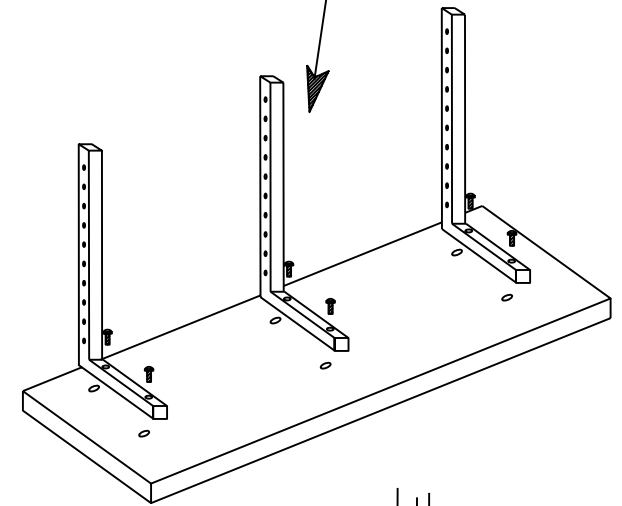

# Studio Furniture Instruction Sheet

## Config-u-raxx Bridges: RB-36, RB46 and RB-60 (including CBS Center Bridge Support)

Raxxess Metalsmiths  
261 Buffalo Avenue  
Paterson, N.J. 07503  
Made with pride in the U.S.A.

Page 2 of 2

Step 2: Pull each of the silver plunger knobs out, then turn, until it stays out. They must all be in the "out" position in order for the shelf to go on. Now, lift the shelf over the table, lining up each of the uprights to go to it's respective reciever, supporting them until they're at the right height, then turn and release the plungers (slightly above where you want it), to stop the shelf.

It may take another try to get the shelf where you like it, but you can change it as time goes on, or to meet your changing needs.

