



EASE
EQUIPMENT ANCHORAGE & SEISMIC ENGINEERING
 2801 Connery Way, Suite B
 Missoula, MT 59808
 Phn: (406) 541-EASE (3273) Fax: (406) 541-3274

Office of Statewide Health Planning and Development
ANCHORAGE PRE-APPROVAL

OPA-2141-07

Equipment Manufacturer: Milestone Inc.

Equipment Type: CMS-440 Projector Mount

GENERAL NOTES

1. FORCES PER ASCE 7-05 SECTION 13.3.1, EQUATIONS 13.3-1, 13.3-2 & 13.3-3, WHERE $S_{DS} = 1.93$, $a_p = 2.5$, $I_p = 1.5$ & $R_p = 2.5$
2. THIS PRE-APPROVAL CONFORMS TO THE 2007 CALIFORNIA BUILDING CODE.
3. THE DETAILS IN THIS PRE-APPROVAL MAY BE USED AT ANY HEIGHT AND AT ANY LOCATION IN THE STATE OF CALIFORNIA.
4. ALL ANCHOR FORCES SHOWN ON THE DRAWINGS ARE WORKING LOADS (AS OPPOSED TO STRENGTH LEVEL LOADS) AND MAY BE USED FOR ALLOWABLE STRESS DESIGN.
5. SHEET METAL SCREWS SHALL BE TEKS SCREWS BY ITW BUILDEX (ICC ESR-1976).
6. PER CAN 2-1708A.5, THIS UNIT DOES NOT REQUIRE "SPECIAL SEISMIC CERTIFICATION".

RESPONSIBILITIES OF THE STRUCTURAL ENGINEER OF RECORD

7. DESIGN BACKING BARS, STUDS, ETC. WHICH THE UNITS ARE ATTACHED TO AS NOTED ON THE DRAWINGS. THE SEOR SHALL ALSO VERIFY THE ADEQUACY OF THE STRUCTURES (SUCH AS WALLS AND FLOORS) WHICH SUPPORT THE UNITS FOR THE LOADS IMPOSED ON THEM BY THE UNITS AS WELL AS ALL OTHER LOADS.
8. PROVIDE ANY SUPPORTING STRUCTURE REQUIRED TO SUPPORT WEIGHTS AND FORCES SHOWN, IN ADDITION TO ALL OTHER LOADS.
9. VERIFY THAT THE INSTALLATION IS IN CONFORMANCE WITH THE 2007 CBC AND WITH THE DETAILS SHOWN IN THIS PRE-APPROVAL. VERIFY THAT THE ACTUAL EQUIPMENT'S WEIGHT, CG LOCATION, ANCHOR LOCATIONS, ANCHOR DETAILS AND THE MATERIAL AND GAGE OF THE UNIT WHERE ATTACHMENTS ARE MADE AGREE WITH THE INFORMATION SHOWN ON THE PRE-APPROVAL DOCUMENTS.

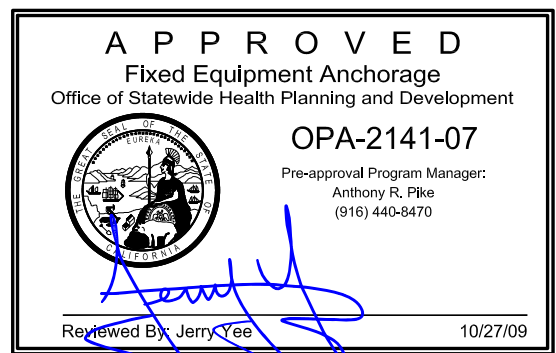

EASE EQUIPMENT ANCHORAGE & SEISMIC ENGINEERING www.equipmentanchorage.com	MILESTONE INC.	DES. R. LA BRIE	SHEET 2
	CMS-440 PROJECTOR MOUNT	JOB 11-0898	OF 3 SHEETS
		DATE 10/27/09	

SEISMIC ANCHORAGE

CEILING MOUNTED

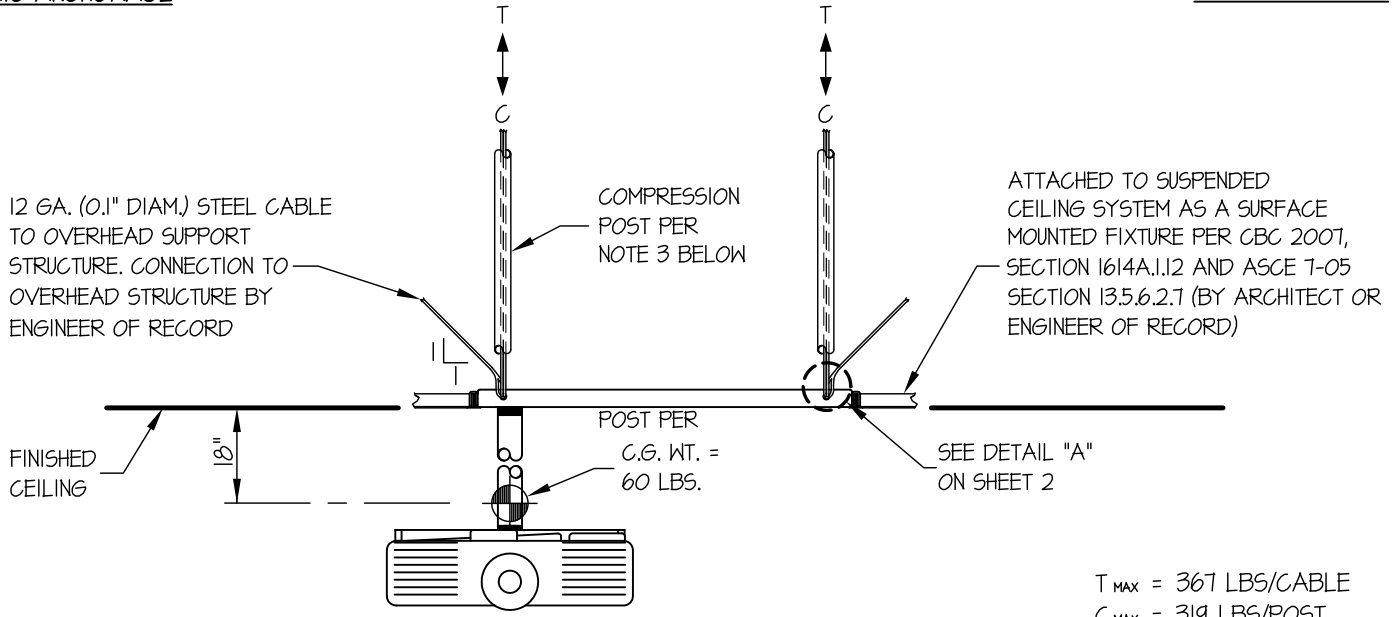

FRONT ELEVATION

NOTES:

1. ANCHORAGE DESIGN PER 2007 CALIFORNIA BUILDING CODE - SECTION 1613A AND ASCE 7-05 SECTIONS 12 AND 13. ALLOWABLE STRESS DESIGN IS USED.
 HORIZONTAL FORCE (E_H) = $2.43 W_p$ ($S_{DS} = 1.93, a_p = 2.5, I_p = 1.5, R_p = 2.5$)
 VERTICAL FORCE (E_v) = $0.27 W_p$
2. CENTER OF GRAVITY (C.G.) WEIGHT IS A MAXIMUM. THIS PRE-APPROVAL ENCOMPASSES ALL WEIGHTS UP TO THE MAXIMUM WEIGHT SHOWN.
3. ENGINEER OF RECORD FOR THE BUILDING SHALL PROVIDE SUPPORT STRUCTURE (INCLUDING COMPRESSION POST AT EACH CORNER) DESIGNED TO SUPPORT WEIGHTS AND FORCES SHOWN, IN ADDITION TO ALL OTHER LOADS.
4. SEE GENERAL NOTES: SHEET 1



A P P R O V E D	
Fixed Equipment Anchorage	
Office of Statewide Health Planning and Development	
	OPA-2141-07
Pre-approval Program Manager: Anthony R. Pike (916) 440-8470	
Reviewed By: Jerry Yee	10/27/09

EASE EQUIPMENT ANCHORAGE & SEISMIC ENGINEERING www.equipmentanchorage.com	MILESTONE INC.	DES. R. LA BRIE	SHEET 3
	CMS-440 PROJECTOR MOUNT	JOB 11-0898	OF 3 SHEETS
		DATE 10/27/09	

SEISMIC ANCHORAGE

CEILING MOUNTED

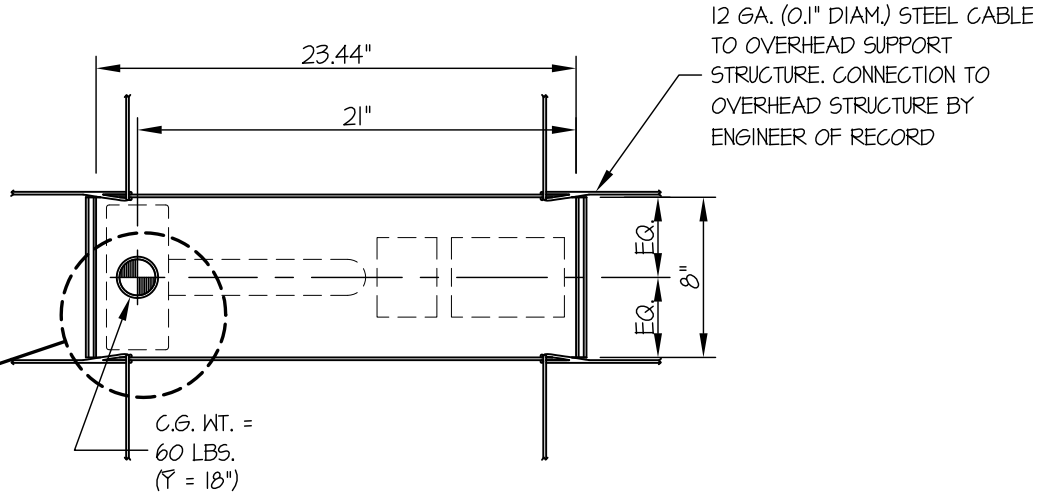

PLAN AT BASE

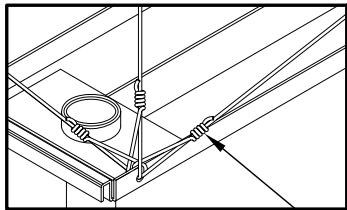

NOTE: PROVIDE 4 TIGHT
TURNS AT WIRE CONNECTION (TYP.)

DETAIL "A"



A P P R O V E D Fixed Equipment Anchorage Office of Statewide Health Planning and Development	
	OPA-2141-07 Pre-approval Program Manager: Anthony R. Pike (916) 440-8470
Reviewed By: Jerry Yee	10/27/09

MILESTONE INC.

CMS-440 PROJECTOR MOUNT

DES. **R. LA BRIE**

JOB **11-0898**

DATE **10/27/09**

SHEET

1

OF **2** SHEETS

SEISMIC ANCHORAGE

CEILING MOUNTED

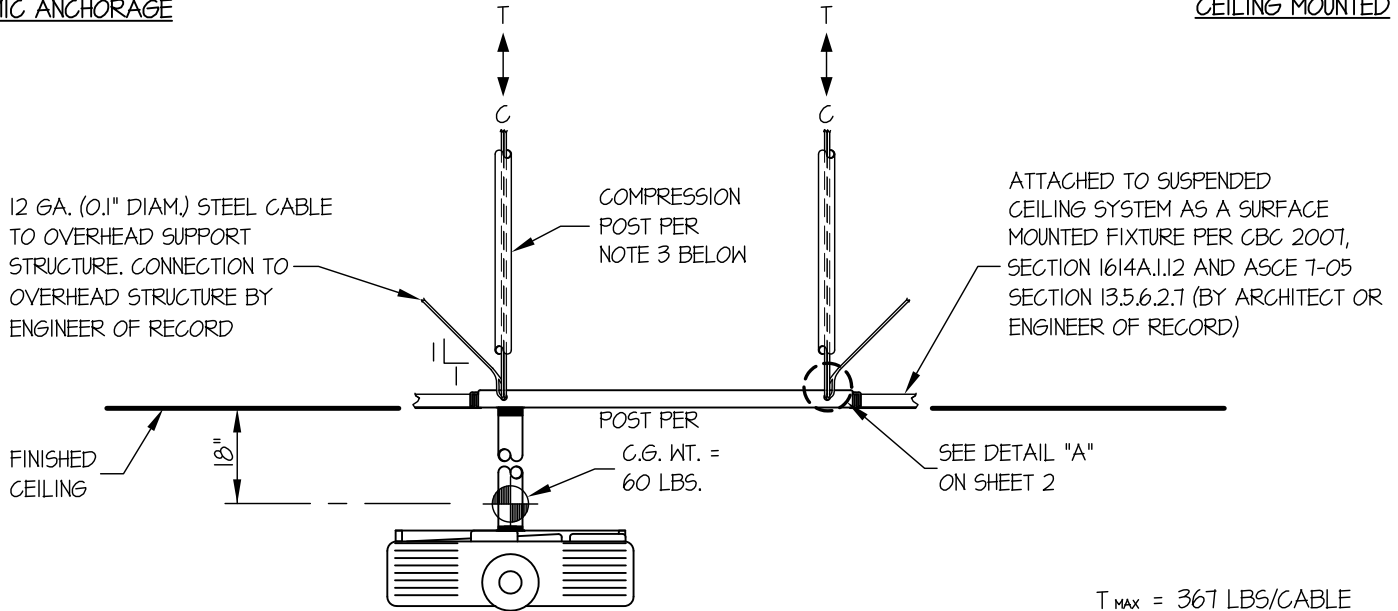

$T_{MAX} = 367 \text{ LBS/CABLE}$
 $C_{MAX} = 319 \text{ LBS/POST}$

FRONT ELEVATION

NOTES:

1. FORCES ARE DETERMINED PER 2007 CALIFORNIA BUILDING CODE SECTION 1613A AND ASCE 7-05 SECTIONS 12 AND 13. ALLOWABLE STRESS DESIGN IS USED.

HORIZONTAL FORCE (E_H) = $2.43 W_p$ ($S_{DS} = 1.93$, $a_p = 2.5$, $I_p = 15$, $R_p = 2.5$)

VERTICAL FORCE (E_v) = $0.27 W_p$

2. CENTER OF GRAVITY (C.G.) WEIGHT IS A MAXIMUM. THIS CALCULATION ENCOMPASSES ALL WEIGHTS UP TO THE MAXIMUM WEIGHT SHOWN.

3. ARCHITECT OR STRUCTURAL ENGINEER OF RECORD SHALL PROVIDE SUPPORT STRUCTURE (INCLUDING COMPRESSION POST AT EACH CORNER) TO SUPPORT WEIGHTS AND FORCES SHOWN.

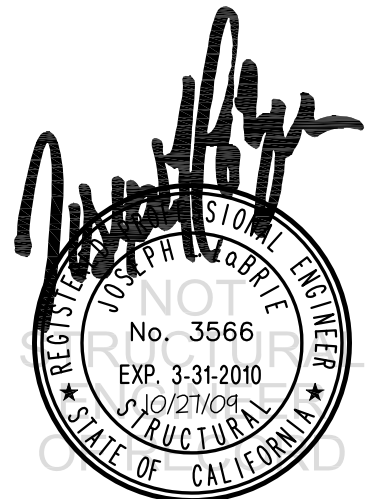

 EASE EQUIPMENT ANCHORAGE & SEISMIC ENGINEERING www.equipmentanchorage.com	MILESTONE INC.	DES. R. LA BRIE	SHEET 2
	CMS-440 PROJECTOR MOUNT	JOB 11-0898	OF 2 SHEETS
		DATE 10/27/09	

SEISMIC ANCHORAGE

CEILING MOUNTED

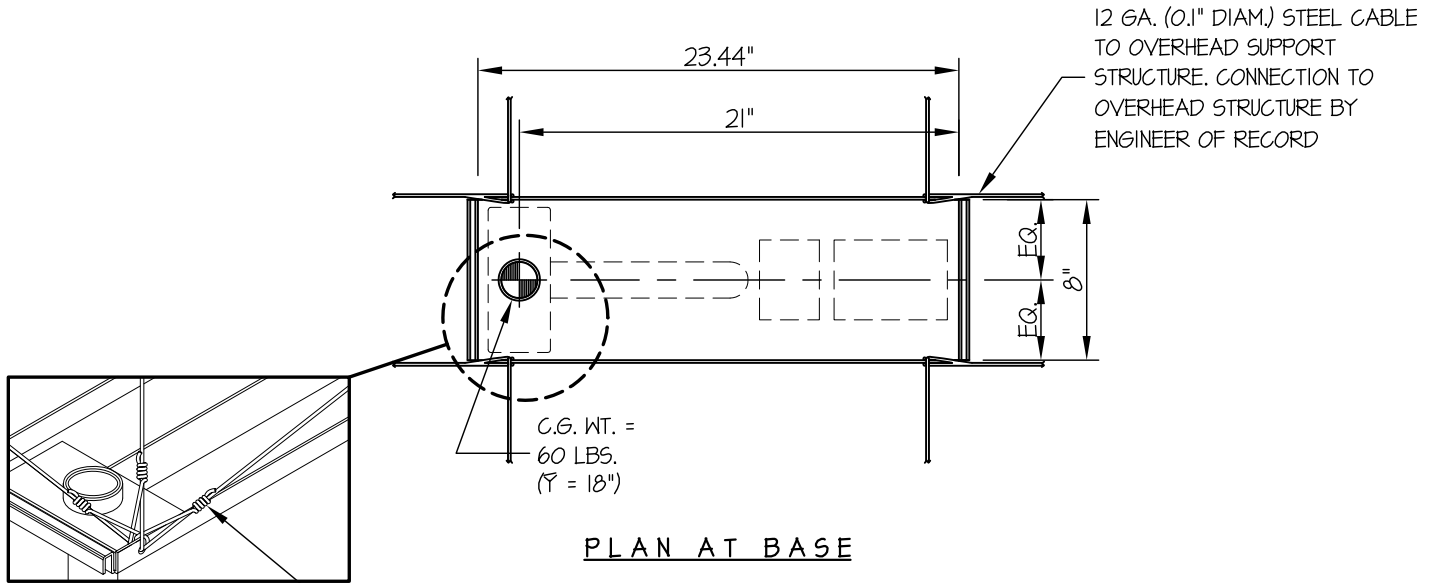

NOTE: PROVIDE 4 TIGHT TURNS AT WIRE CONNECTION (TYP.)

DETAIL "A"

LOADS:

WEIGHT = 60 LBS (INCLUDES 50# MAX PROJECTOR)

HORIZONTAL FORCE (E_H) = $2.43 W_p = 146$ LBS

VERTICAL FORCE (E_V) = $0.27 W_p = 16$ LBS

TENSION (T)

$$T = \frac{146\#(18")}{8"} + \frac{60\# + 16\#}{2 \text{ CABLES}} = 367 \text{ LBS/CABLE (MAX)}$$

$$C = \frac{146\#(18")}{8"} + \frac{60\#(0.6) + 16\#}{2 \text{ POSTS}} = 319 \text{ LBS/POST (MAX)}$$

NOTE:

PROVIDE CEILING STRUCTURE DESIGNED TO SUPPORT WEIGHTS AND FORCES SHOWN. (BY ENGINEER OF RECORD FOR THE BUILDING)